

Oban Dining Table 180x90 cm Assembly Instructions

Thank you for purchasing this Oban Dining Table. Please read the instructions carefully before use to ensure safe and satisfactory operation of this product

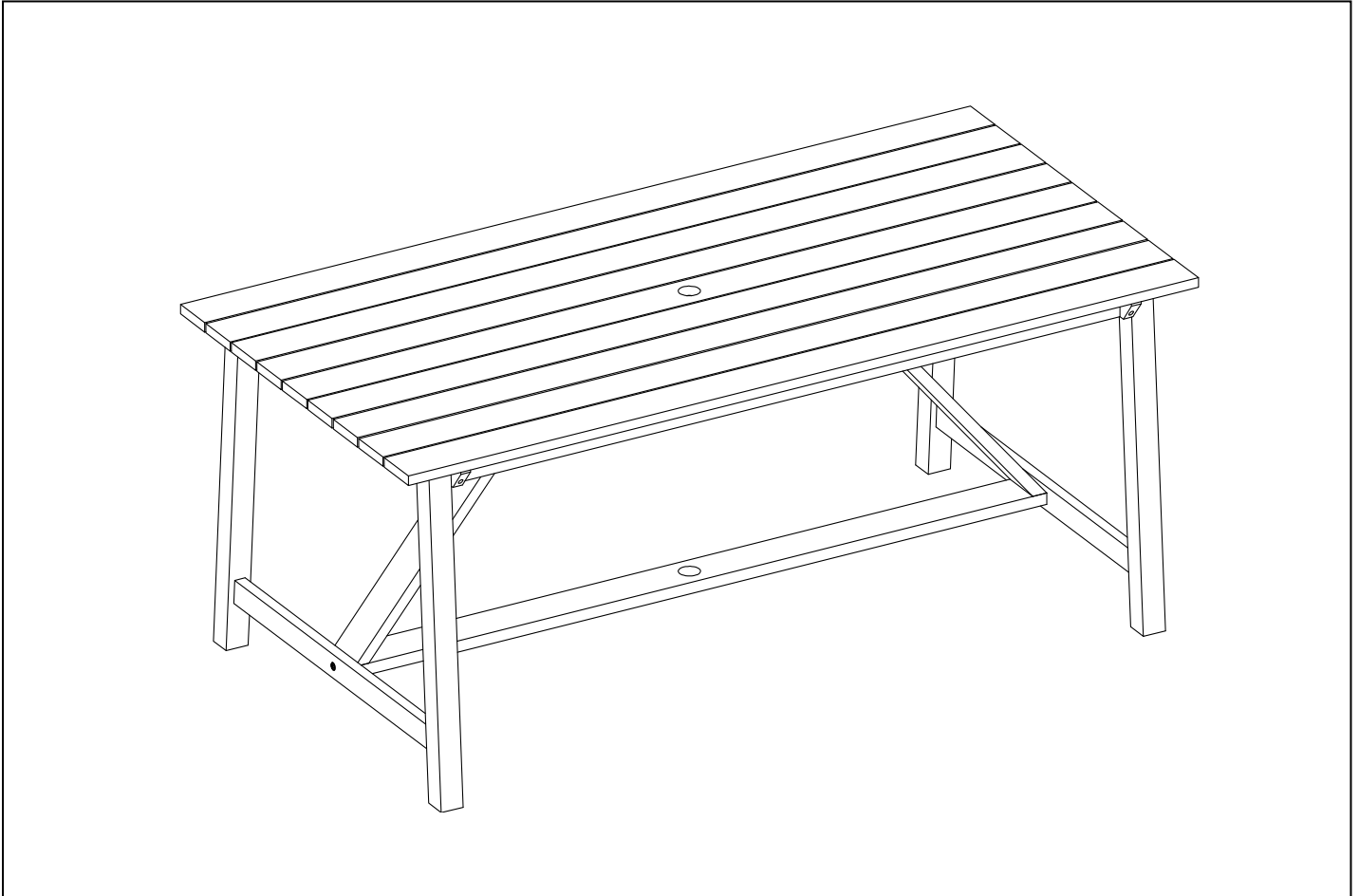

If you need help with assembly or missing parts please call our customer care team on: 01344 578 000
9am-5pm Monday to Friday.



Component Parts

Please check if you have all the parts as listed below. **Note.** The quantities below are the correct amount to complete the assembly. In some cases more fittings may be supplied than are required.

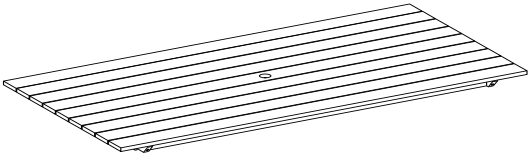
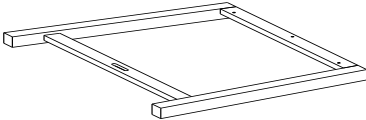
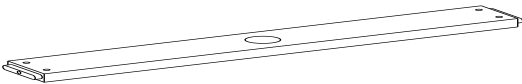
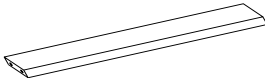
Component Check list

A		Top x 1
B		Leg x 2
C		Cross bar x 1
D		Strut bar x 2

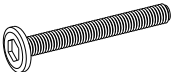
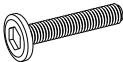
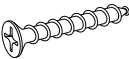
Hardware Check list

E		6x45 Bolt x 6
F		6 x 55 bolt x2
G		6 x 35 bolt x4
H		Screw x 4
I		Hex Key x 1
J	Cross head screw driver	not provided in the hardware pack

Assembly Requirements

Number of people required to assemble	2
Approximate assembly time	40 minutes

If you need help with assembly or missing parts please call our customer care team on: 01344 578 000
9am-5pm Monday to Friday.

Assembly Instructions

Step 1

Place the table top (A) upside down on a flat, clean, dry & smooth surface that will not scratch the furniture.

Attach the Leg (B) to top (A) by using 6 x Bolt (E). Tighten the bolts by using the Hex Key (I), but **DO NOT** fully tighten the bolts at this stage

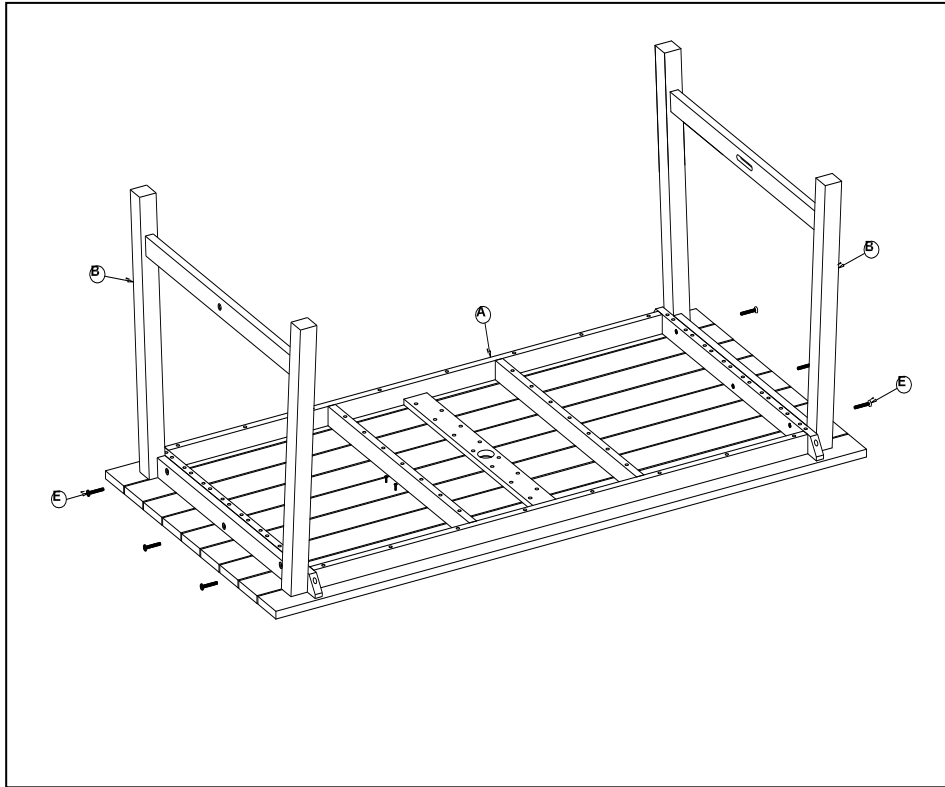

Step 2

Align the cross bar (C) to leg frame (B) as shown in the diagram.

Use 2 x Bolt (F) to connect the Cross bar (C) to the leg frames (B). Tighten all the bolts using the Hex Key (I)

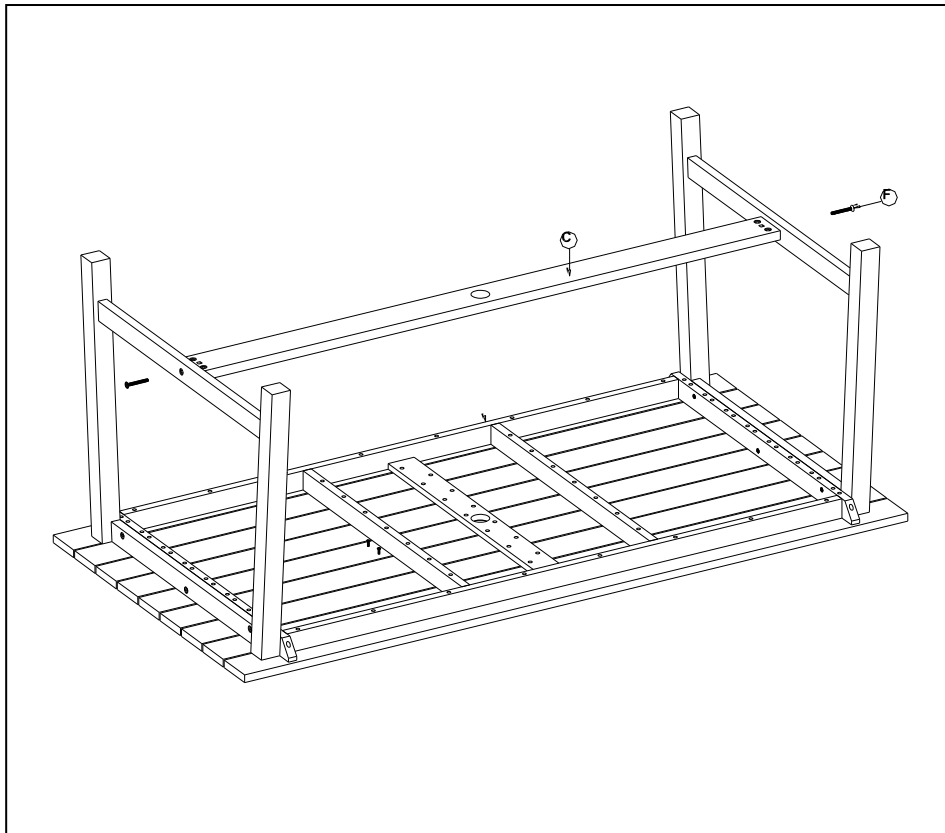

If you need help with assembly or missing parts please call our customer care team on: 01344 578 000
9am-5pm Monday to Friday.

Step 3

Use the 4 x bolt (G) to connect the strut bar (D) to the cross bar (C). Tighten the bolts by using the Hex Key (I), but **DO NOT** fully tightened the bolts at this stage.

Use the 4 x Screws (H) to connect the other side of strut bar (D) to table top (A). Use a Cross Head screw driver (J) (**not provided in the hardware pack**) to tighten all screws.

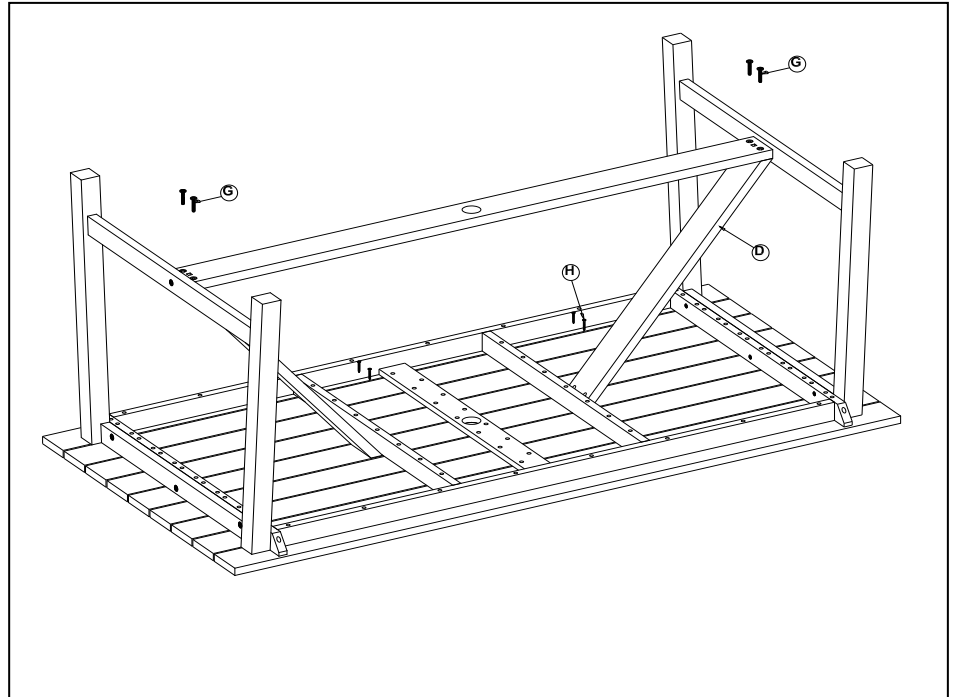

Step 4

With the help of another person, carefully turn the table the right way up, taking care not to pivot on the legs. Place the table on an even level surface ensuring that each leg is in full contact with the ground.

Ensure that all bolts and screws are fully tightened.

The table is now ready to use.

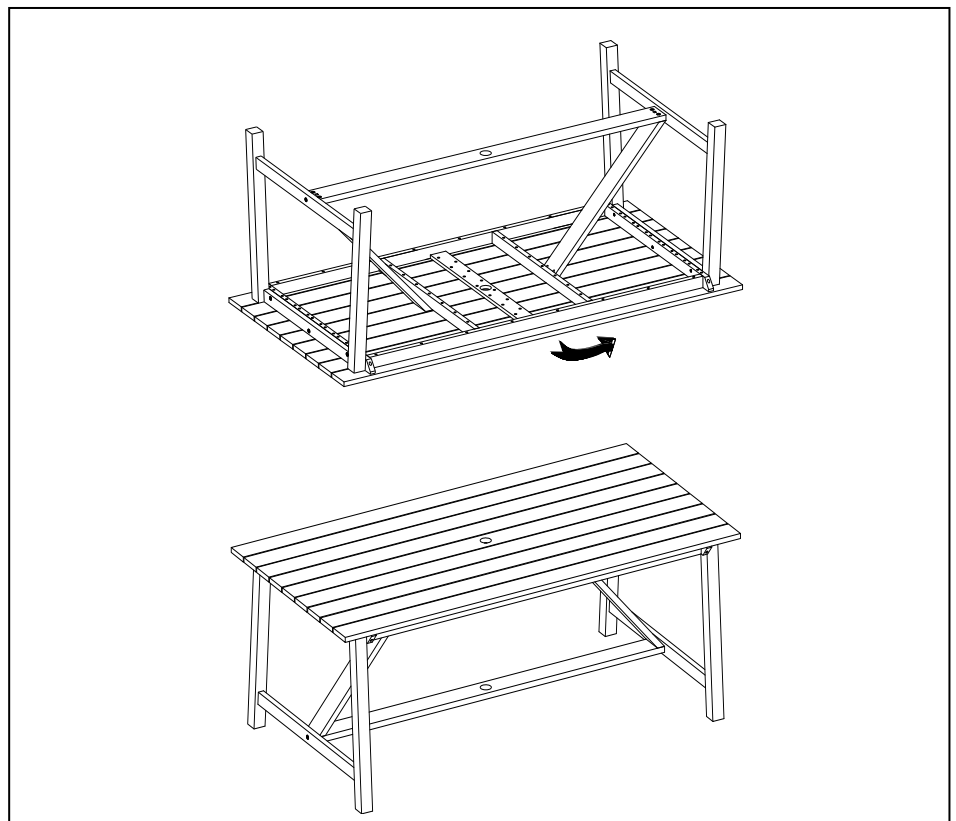

Wood Furniture

This product is made from Eucalyptus FSC and has been painted and sealed with PU paint, suitable for outdoor use.

Wood displays different grain patterns depending on which way they cut - for example, the 'medullary ray' which can appear on oak furniture is a mark of good quality timber - these are just characteristics of the natural beauty of the wood. Some furniture is also deliberately aged and rustic.

All timber surfaces will change colour and mellow over time. New furniture will initially vary in shade from items that have been previously purchased.

Safety and Care Advice

To extend the product life and appearance it is advisable to store the furniture in a cool dry place over winter or during periods of unseasonal weather. Ensure that the furniture is clean and completely dry before putting in to storage. Do NOT enclose the product in a plastic or other non-permeable material as this promotes the growth of mildew and mould. Cover it with a dust sheet or furniture cover allowing the air to circulate around it

In order to enhance the life of your table clean regularly with a very mild warm soapy solution to remove dirt and grease and acidic animal droppings. Do not use strong detergents. Do not jet spray the furniture to avoid damaging the paint finish. You may experience some minor surface cracking as the timber expands and contracts in times of changes of humidity but these will not affect the structural performance of your table.

Important safety note

- Never drag furniture when moving it, always lift it.
- Periodically check all fixings to ensure none have come loose and re-tighten where necessary.
- Please take care when handling or moving the furniture as careless handling may cause damage or injury
- Ensure that the furniture is always on a solid and level surface and the legs are in contact with the ground at all times.

Do NOT:

- Use the table as a ladder
- Stand or jump on the table top
- Sit on the table top.

PLEASE KEEP THESE INSTRUCTIONS FOR FUTURE REFERENCE

If you need help with assembly or missing parts please call our customer care team on: 01344 578 000
9am-5pm Monday to Friday.

Oban Wooden Dining Chair Assembly Instructions

Thank you for purchasing this Oban Wooden Dining Chair. Please read the instructions carefully before use to ensure safe and satisfactory operation of this product

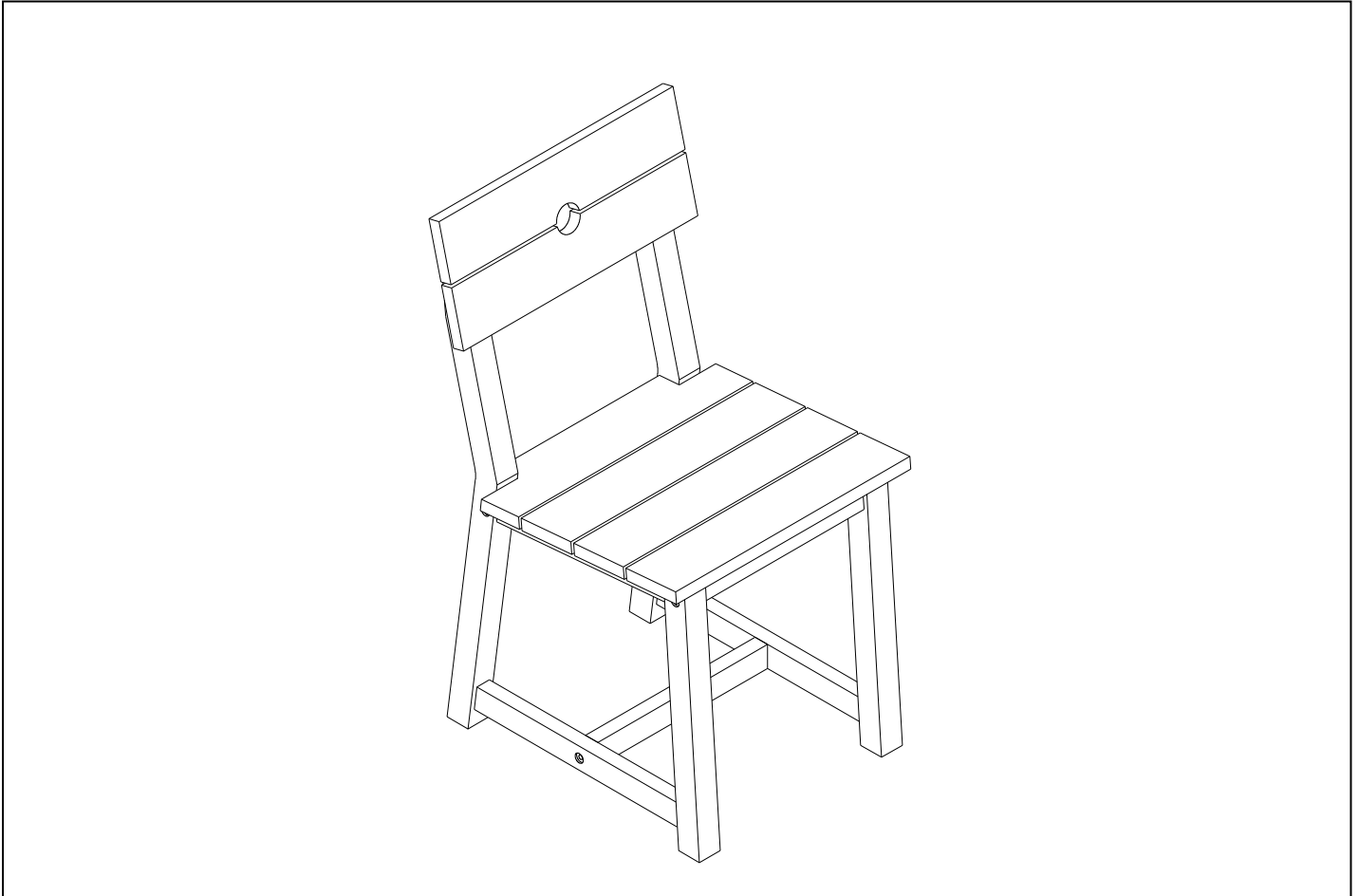

If you need help with assembly or missing parts please call our customer care team on: 01344 578 000
9am-5pm Monday to Friday.



Component Parts

Please check if you have all the parts as listed below. **Note.** The quantities below are the correct amount to complete the assembly. In some cases more fittings may be supplied than are required.

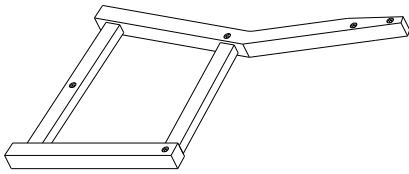
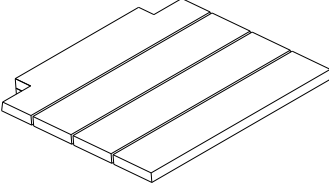
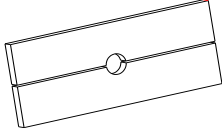
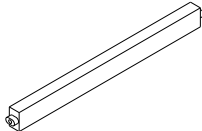
Component Check list

A		Side Frame x 2
B		Seat x 1
C		Back x 1
D		Cross Bar x 1

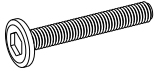
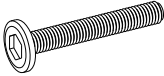
Hardware Check list

E		6x70 Bolt x 4
F		6 x 50 bolt x4
G		6 x 55 bolt x2
H		Hex Key x 1

Assembly Requirements

Number of people required to assemble	1
Approximate assembly time	30 minutes

If you need help with assembly or missing parts please call our customer care team on: 01344 578 000
9am-5pm Monday to Friday.

Assembly Instructions

Step 1

Place the Chair on a flat, clean, dry & smooth surface that will not scratch the furniture.

Attach the Back (C) to the Side Frame (A) by using 2 x Bolt (F). Tighten the bolts by using the Hex Key (H), but **DO NOT** fully tighten the bolts at this stage

Attach the Seat (B) and the Cross Bar (D) to the Side Frame (A) by using 2 x Bolt (E) and 1 x bolt (G). Tighten all the bolts using the Hex Key (H)

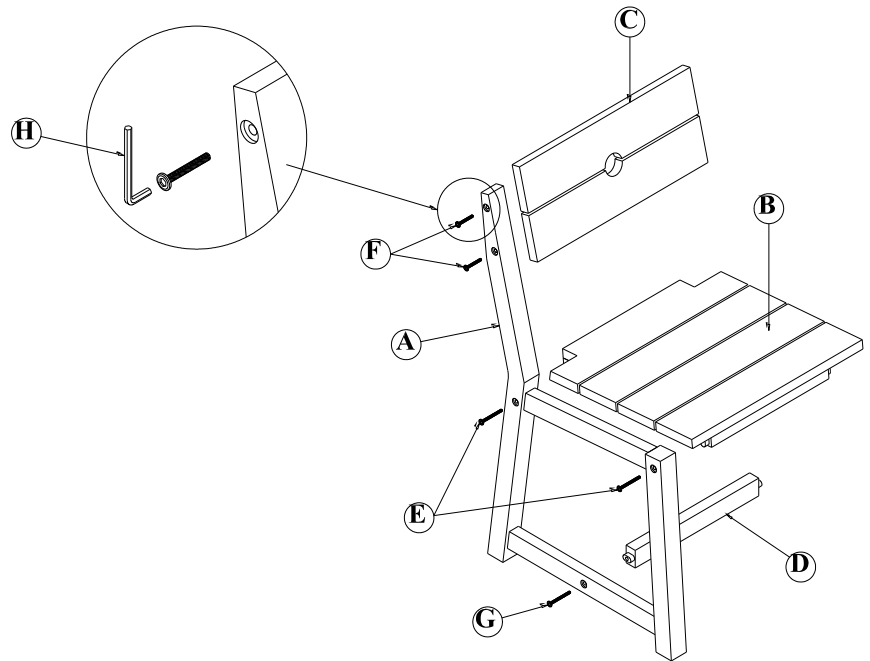

Step 2

Align the remaining Side Frame (A) with the constructed frame as shown in the diagram.

Use 2 x Bolt (F) to connect the Back (C) to the Side Frame (A)

Use 2 x Bolt (E) to connect the Side Frame (A) to the Seat (B), then use 1 x bolt (G) to connect side frame A to Cross bar (D). Tighten all the bolts using the Hex Key (H)

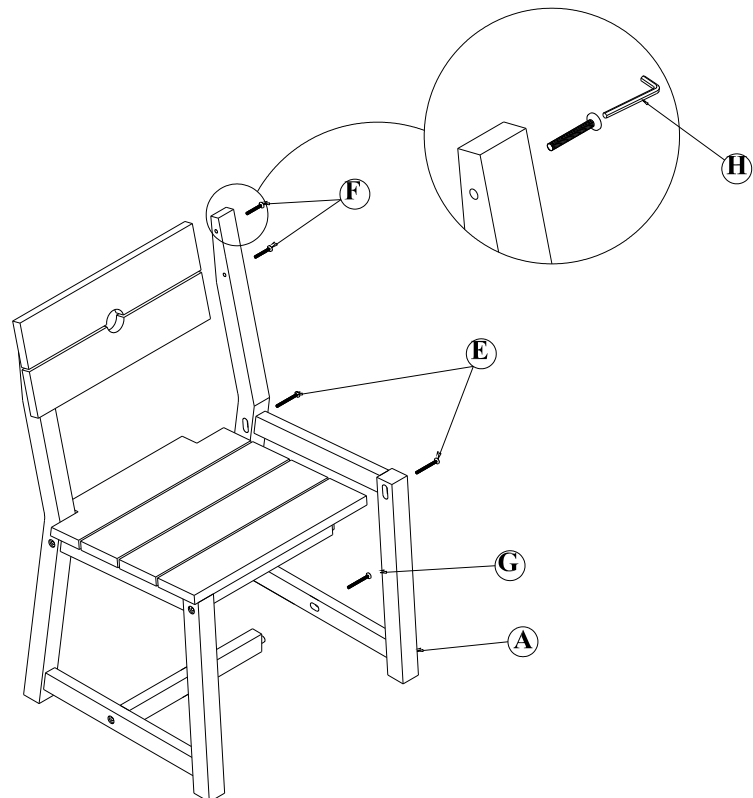

If you need help with assembly or missing parts please call our customer care team on: 01344 578 000
9am-5pm Monday to Friday.

Assembly Instructions

Step 3

Ensure that all bolts are fully tightened.

The chair is now ready to use.

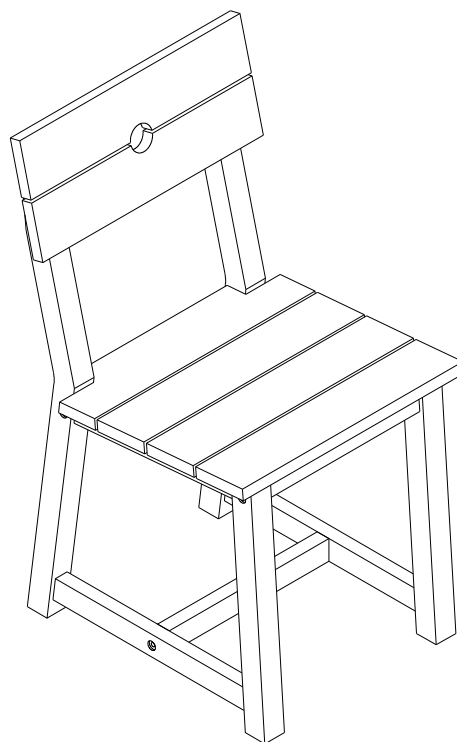

If you need help with assembly or missing parts please call our customer care team on: 01344 578 000
9am-5pm Monday to Friday.

Wood Furniture

This product is made from Eucalyptus FSC and has been painted and sealed with PU paint, suitable for outdoor use.

Wood displays different grain patterns depending on which way they cut - for example, the 'medullary ray' which can appear on oak furniture is a mark of good quality timber - these are just characteristics of the natural beauty of the wood. Some furniture is also deliberately aged and rustic.

All timber surfaces will change colour and mellow over time. New furniture will initially vary in shade from items that have been previously purchased.

Safety and Care Advice

To extend the product life and appearance it is advisable to store the furniture in a cool dry place over winter or during periods of unseasonal weather. Ensure that the furniture is clean and completely dry before putting in to storage. Do NOT enclose the product in a plastic or other non-permeable material as this promotes the growth of mildew and mould. Cover it with a dust sheet or furniture cover allowing the air to circulate around it

In order to enhance the life of your chair clean regularly with a very mild warm soapy solution to remove dirt and grease and acidic animal droppings. Do not use strong detergents. Do not jet spray the furniture to avoid damaging the paint finish. You may experience some minor surface cracking as the timber expands and contracts in times of changes of humidity but these will not affect the structural performance of your chair.

Important safety note

- Never drag furniture when moving it, always lift it.
- Periodically check all fixings to ensure none have come loose and re-tighten where necessary.
- Please take care when handling or moving the furniture as careless handling may cause damage or injury
- Ensure that the furniture is always on a solid and level surface and the legs are in contact with the ground at all times.

Do NOT:

- Use the chair as a ladder
- Stand or jump on the chair
- Sit on back of the chair

PLEASE KEEP THESE INSTRUCTIONS FOR FUTURE REFERENCE

If you need help with assembly or missing parts please call our customer care team on: 01344 578 000
9am-5pm Monday to Friday.